

Location: \_\_\_\_\_



**CESHW**

**WIDEBODY HEAVY LOAD SERIES**

**Specification:**

**Dimensions**

Base - 12" Width x 12" Length

**Material**

Rubber Base - 100% recycled rubber, UV resistant

Base Strut - 14 gauge galvanized steel

Crossbeam - 1 5/8" x 3 1/4", 12 gauge galvanized steel, back to back strut

Upright - 1 5/8" x 1 5/8", 12 gauge galvanized steel strut

**Maximum Load** - 800 lbs.



**Environmentally Friendly  
made from 100% recycled tires**

**Function:** The CESHW Series can support gas and refrigeration piping systems, cable tray, electrical conduit, multiple lines, HVAC equipment and many other applications. It is designed for rooftop applications requiring a heavier load bearing, and is suitable for most types of roofing material or other flat surfaces.



**CESHW-1624**

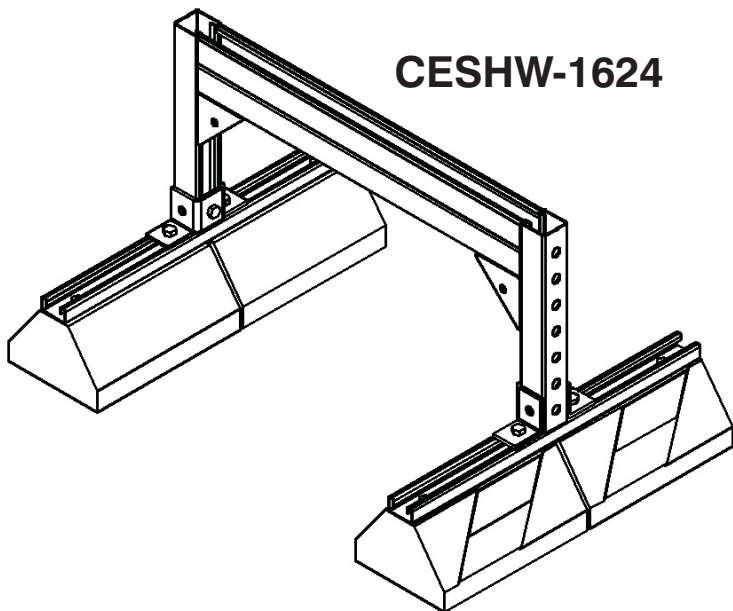

Note: CESHW-1624 illustrated. Pipe clamp by others.

MODEL #	Height (H)	Width (W)	Base Height & Width	Weight
CESHW-1624	16" (406)	24" (610)	12" (305)	37 lbs.
CESHW-1636	16" (406)	36" (914)	12" (305)	39 lbs.

Channel also available in corrosion resistant stainless steel or aluminum.

Job Name: _____	Page No: _____
Section No: _____	Contractor: _____
Schedule No: _____	Purchase Order No: _____

MIFAB reserves the right to make changes in material and design without formal notice and obligation.

USA: 1-800-465-2736 www.mifab.com CAN: 1-800-387-3880