

Location: _____



CESW

WIDEBODY, MEDIUM LOAD SERIES

Specification:

Dimensions - 24" Crossbeam Width x 12" Base Length x 24" to 48" Height (See Chart)

Material

Base - 100% recycled rubber, UV resistant

Crossbeam and Uprights - 1 5/8" x 1 5/8", 12 gauge galvanized steel strut

Maximum Load - 600 lbs.



**Environmentally Friendly
made from 100% recycled tires**

Function: The CESW Series can support gas and refrigeration piping systems, cable tray, electrical conduit, multiple lines, HVAC equipment and many other applications. It is designed for rooftop applications requiring a heavier load bearing, and is suitable for most types of roofing material or other flat surfaces. The wide bases provide this series with added stability. The CESW Series is suitable for use with one or two pipe hangars (by others).

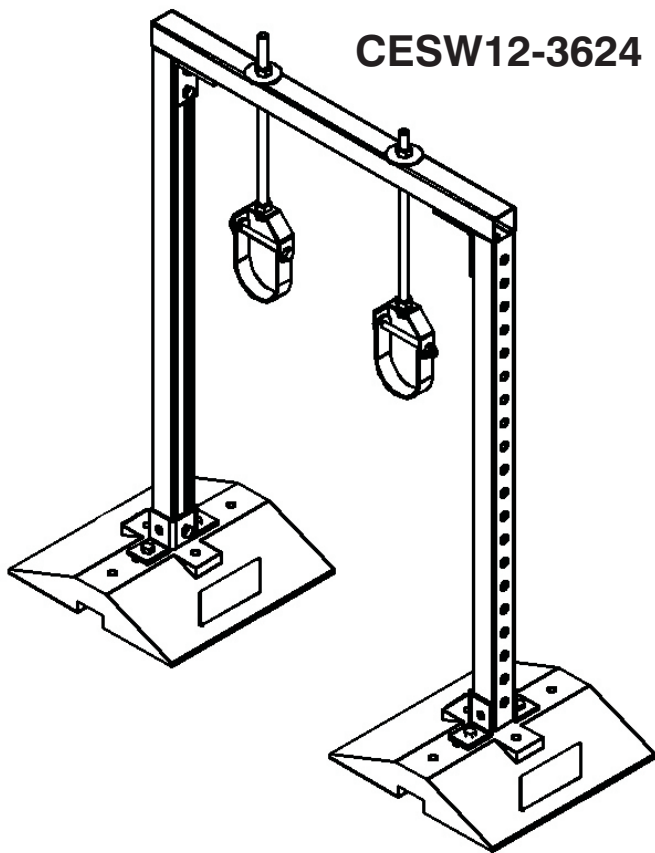

Note: CESW12-2424 illustrated. Pipe hangars by others.

MODEL #	Height (H)	Crossbeam Width	Base Width	Base Length	Weight
CESW12-2424	24" (610)	24" (610)	12" (305)	12" (305)	27.80 lbs.
CESW12-3624	36" (914)	24" (610)	12" (305)	12" (305)	31.12 lbs.
CESW12-4824	48" (1219)	24" (610)	12" (305)	12" (305)	34.44 lbs.

Channel also available in corrosion resistant stainless steel or aluminum.

Job Name: _____	Page No: _____
Section No: _____	Contractor: _____
Schedule No: _____	Purchase Order No: _____

MIFAB reserves the right to make changes in material and design without formal notice and obligation.

USA: 1-800-465-2736 www.mifab.com CAN: 1-800-387-3880