

Air-Port Utility Pads

Specification Sheet:

Dimensions - 2" High x 5" Wide x Length (base length)

Material

Base: 100% recycled rubber, UV-resistant

Weight - 7.12 lbs (AP24), 12.14 lbs (AP36)

- Designed to provide support for all electrical and HVAC equipment.
- Grooved recessed tray prevents movement and dampens vibration.
- Allows water passage; Prevents growth of moss and mold.
- Lightweight.

Maximum Load - 500 lbs (all sizes)

*Consult roofing manufacturer or engineer for roof loading.

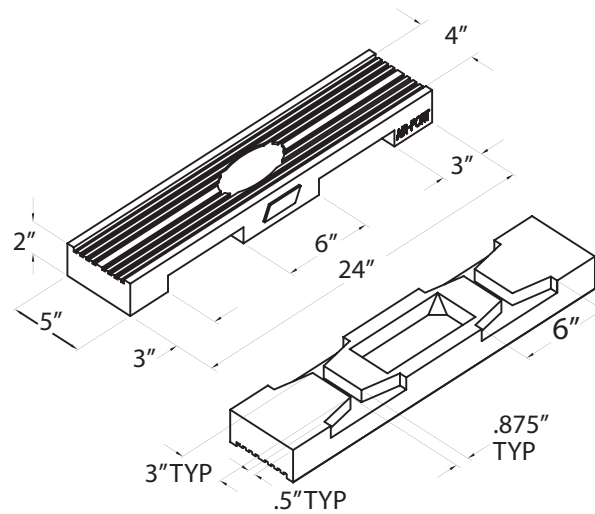

VIEW ON UNDERSIDE

MODEL #	Height (H)	Width (W)	Length (L)	Weight
AP24	2" (50mm)	5" (126mm)	24" (610mm)	7.12 LBS
AP36	2" (50mm)	5" (126mm)	36" (914mm)	12.14 LBS

MIFAB, Inc. 1321 West 119th Street, Chicago Illinois 60643-5109, USA
Tel: 1-800-465-2736 Fax: 773-341-3049

www.mifab.com