

Location: \_\_\_\_\_



**CR**

**ROLLER SERIES, REGULAR BASE**

**Specification:**

**Dimensions**

Base - Width of 6" x Length of 9.6"

Roller Width - 3", 4", or 6" rollers are available (See Chart)

Total Height to Roller Centre - ranges from 5.75" to 6.5" (See Chart)

**Material**

Base - 100% recycled rubber, UV resistant

Roller - rubber (cast iron galvanized rollers for 6" pipe are also available)

**Maximum Load** - 500 lbs.



**Environmentally Friendly  
made from 100% recycled tires**

**Function:** The CR Series is designed for superior support of gas and refrigeration pipes. The roller allows for longitudinal movements of the pipe. This support is suitable for most types of roofing material or other flat surfaces.

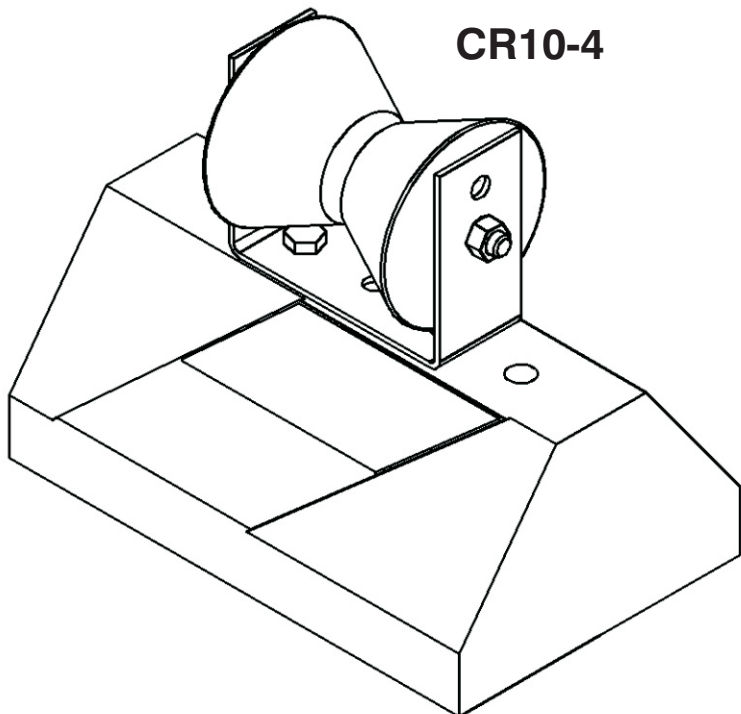
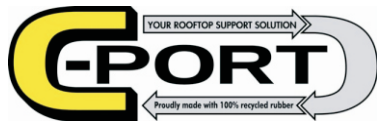

**CR10-4**



Note: CR10-4 illustrated

MODEL #	Pipe Size (OD)	Overall Height (H) to Roller Centre	Width (W)	Length (L)	Weight
CR10-3	Up to 3" Pipe	6.5" (165)	6" (152)	9.6" (244)	6.10 lbs.
CR10-4	3" to 4" Pipe	6.5" (165)	6" (152)	9.6" (244)	6.44 lbs.

Also available with a 3" or 4" rubber roller, or a 6" cast iron galvanized roller.

Job Name: _____	Page No: _____
Section No: _____	Contractor: _____
Schedule No: _____	Purchase Order No: _____

MIFAB reserves the right to make changes in material and design without formal notice and obligation.

USA: 1-800-465-2736 www.mifab.com CAN: 1-800-387-3880