

Location: _____



CRE

**EXTENDED
ROLLER SERIES, REGULAR BASE**

Specification:

Dimensions

Base - Width of 6" x Length of 9.6"
 Roller Width - 3", 4", or 6" rollers are available (See Chart)
 Total Height to Roller Centre - ranges from 8" to 12" (See Chart)

Material

Base - 100% recycled rubber, UV resistant
 Roller - rubber (cast iron galvanized rollers for 6" pipe are also available)
 Extending Rods and Horizontal Rod - 1/2" electro zinc plated all threaded rod risers

Maximum Load - 300 lbs.



**Environmentally Friendly
made from 100% recycled tires**

Function: The CRE Series is designed for superior support of gas and refrigeration pipes at a higher elevation from the roof surface. The roller allows for longitudinal movements of the pipe. This support is suitable for most types of roofing material or other flat surfaces.



CRE10-12-2

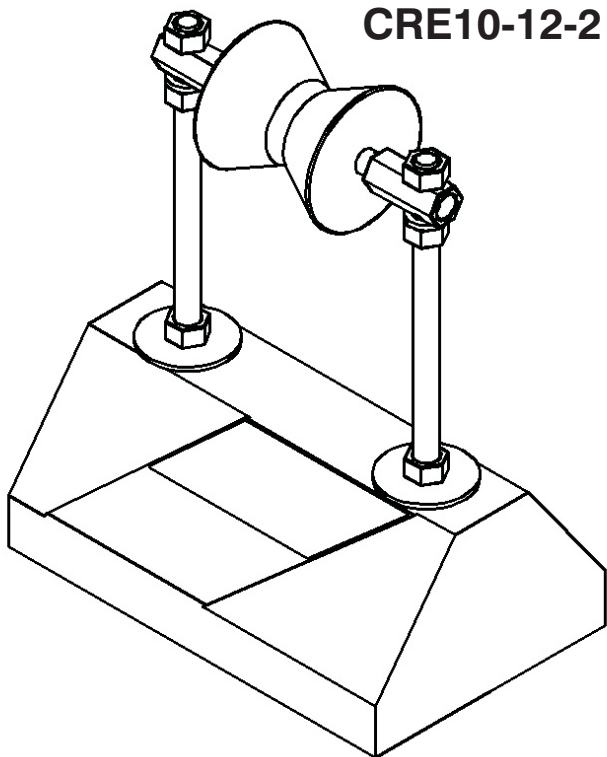

Note: CRE10-8-3 illustrated

MODEL #	Pipe Size (OD)	Overall Height (H) to Roller Centre	Width (W)	Length (L)	Weight
CRE10-8-3	Up to 3" Pipe	8" (203)	6" (152)	9.6" (244)	6.70 lbs.
CRE10-8-4	3" to 4" Pipe	8" (203)	6" (152)	9.6" (244)	7.45 lbs.
CRE10-12-3	Up to 3" Pipe	12" (305)	6" (152)	9.6" (244)	7.10 lbs.

Also available with a 3" or 4" rubber roller, or a 6" cast iron galvanized roller (except for CRM).

Job Name: _____	Page No: _____
Section No: _____	Contractor: _____
Schedule No: _____	Purchase Order No: _____

MIFAB reserves the right to make changes in material and design without formal notice and obligation.

USA: 1-800-465-2736 www.mifab.com CAN: 1-800-387-3880