

Location: _____



CREW

**EXTENDED ROLLER SERIES,
WIDEBODY BASE**

Specification:

Dimensions

Base - 12" Width x 12" Length
 Roller Width - 3", 4", or 6" (See Chart)
 Total Height to Roller Centre - 12" or 16" (See Chart)

Material

Base - 100% recycled rubber, UV resistant
 Roller - rubber (cast iron galvanized rollers for 6" pipe are also available)
 The extending rods, as well as the horizontal rod that the roller rests on, are all 1/2" electro zinc plated all threaded rod risers
Maximum Load - 500 lbs.



**Environmentally Friendly
made from 100% recycled tires**

Function: The CREW Series support is designed for superior support of gas and refrigeration pipes. The roller allows for longitudinal movements of the pipe. The wide-bodied base provides additional stability and load-bearing capacity. This support is suitable for most types of roofing material or other flat surfaces.



CREW12-12-4

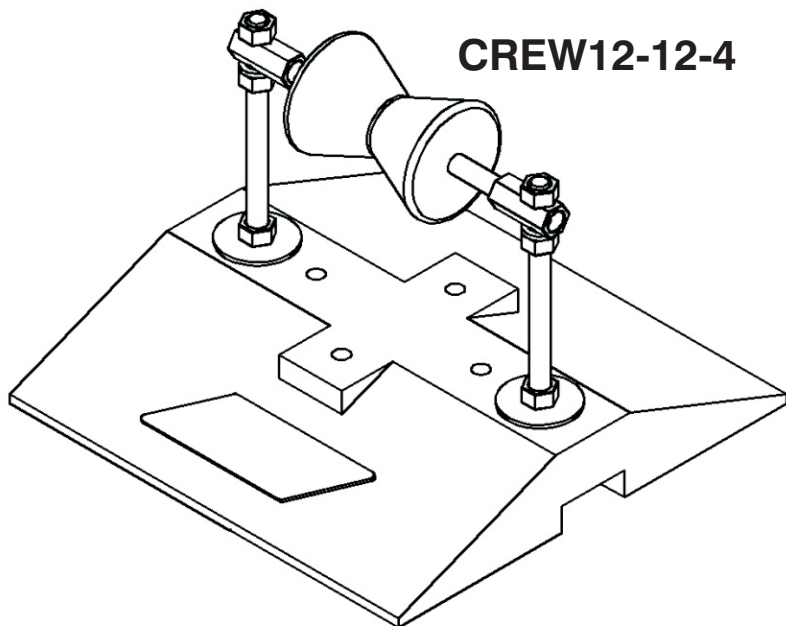

Note: CREW12-12-3 illustrated

MODEL #	Pipe Size (OD)	Overall Height (H) to Roller Centre	Width (W)	Length (L)	Weight
CREW12-12-3	Up to 3"	12" (305)	12" (305)	12" (305)	11.3 lbs.
CREW12-12-4	3" to 4"	12" (305)	12" (305)	12" (305)	11.5 lbs.
CREW12-12-6	4" to 6"	12" (305)	12" (305)	12" (305)	13.0 lbs.
CREW12-16-3	Up to 3"	16" (406)	12" (305)	12" (305)	11.5 lbs.
CREW12-16-4	3" to 4"	16" (406)	12" (305)	12" (305)	11.7 lbs.
CREW12-16-6	4" to 6"	16" (406)	12" (305)	12" (305)	13.5 lbs.

Also available with a 3" or 4" rubber roller, or a 6" cast iron galvanized roller.

Job Name: _____ Page No: _____
 Section No: _____ Contractor: _____
 Schedule No: _____ Purchase Order No: _____

MIFAB reserves the right to make changes in material and design without formal notice and obligation.

USA: 1-800-465-2736 www.mifab.com CAN: 1-800-387-3880