

Location: \_\_\_\_\_



**CRM**

**ROLLER SERIES, SMALL BASE**

**Specification:**

**Material**

Base - 100% recycled rubber, UV resistant

Roller - rubber

**Maximum Load** - 300 lbs.



**Environmentally Friendly  
made from 100% recycled tires**

**Function:** The CRM Series is designed for superior support of gas and refrigeration pipes at a higher elevation from the roof surface. The roller allows for longitudinal movements of the pipe. The CRM provides a less expensive alternative to the larger roller series products. It is suitable for most types of roofing material or other flat surfaces, and is ideal for smaller pipes.

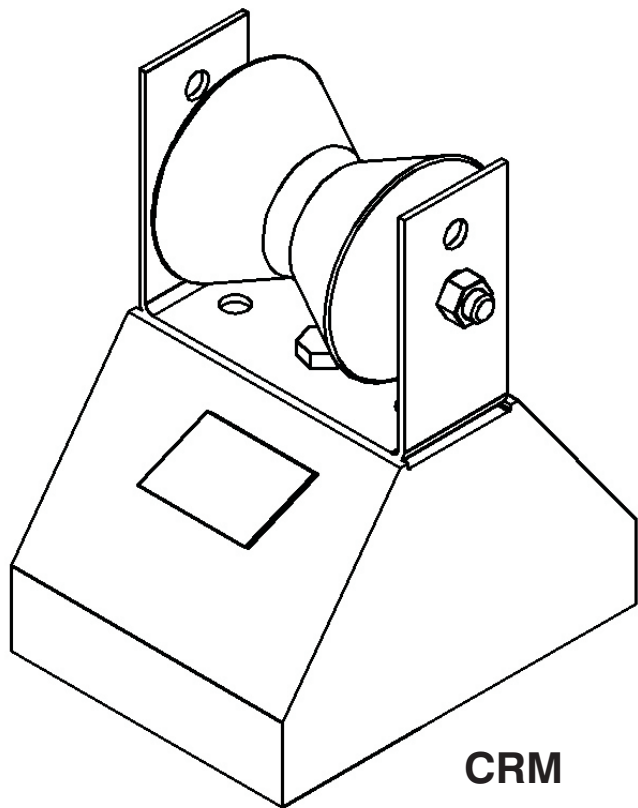

**CRM**



MODEL #	Pipe Size (OD)	Overall Height (H) to Roller Centre	Width (W)	Length (L)	Weight
CRM	Up to 3" Pipe	5.75" (146)	6" (152)	4.5" (114)	3.80 lbs.

Job Name: _____	Page No: _____
Section No: _____	Contractor: _____
Schedule No: _____	Purchase Order No: _____

MIFAB reserves the right to make changes in material and design without formal notice and obligation.

USA: 1-800-465-2736 www.mifab.com CAN: 1-800-387-3880