

Location: _____



CW

**WIDEBODY SERIES WITH
1 5/8" x 13/16" GALVANIZED CHANNEL**

Specification:

Dimensions - 3.3125" Height x 12" Width x Length as specified in chart

Material

Base - 100% recycled rubber, UV resistant

Strut - 14 gauge galvanized steel

Maximum Load - 1,000 lbs. - for each 12" long support



**Environmentally Friendly
made from 100% recycled tires**

Function: The CW Series is designed for superior support of gas and refrigeration piping systems, cable tray, electrical conduit, multiple lines, HVAC equipment and many other applications. The wide body of the base gives this support series superior stability and load-bearing capability. It is suitable for most types of roofing material or other flat surfaces.



Note: CW12 illustrated. Pipe clamp by others.

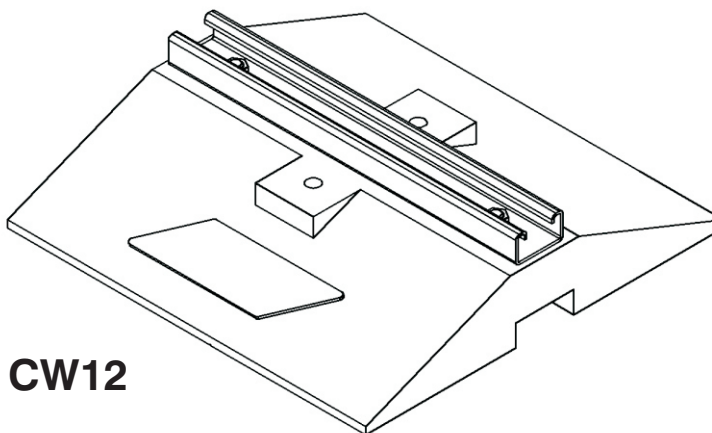

CW12

MODEL #	HEIGHT (H)	WIDTH (W)	LENGTH (L)	WEIGHT
CW12	3.3125" (84)	12" (305)	12" (305)	9.5 lbs.
CW24	3.3125" (84)	12" (305)	24" (610)	19.0 lbs.
CW36	3.3125" (84)	12" (305)	36" (914)	28.5 lbs.
CW48	3.3125" (84)	12" (305)	48" (1219)	38.0 lbs.
CW60	3.3125" (84)	12" (305)	60" (1524)	47.5 lbs.
CW72	3.3125" (84)	12" (305)	72" (1829)	57.0 lbs.

Channel also available in corrosion resistant stainless steel or aluminum.

Job Name: _____	Page No: _____
Section No: _____	Contractor: _____
Schedule No: _____	Purchase Order No: _____

MIFAB reserves the right to make changes in material and design without formal notice and obligation.