

Location: \_\_\_\_\_



# F1100-C-SD

## FLOOR DRAIN WITH SQUARE SOLID HINGED COVER FOR MEMBRANE FLOOR AREAS

**Specification:** MIFAB Series F1100-C-SD lacquered cast iron floor drain with anchor flange, cast iron membrane clamp ring with primary and secondary weepholes for waterproofing membrane, and standard reinforced, ("SD6") square 6" x 6" (152 x 152) (specify material finish) strainer with solid hinged cover and secondary grate. (For non-membrane floors, use MIFAB F1100-SD Series.)

**Function:** Used in showers, kitchens, restrooms and other membrane finished areas where infrequent drain use is required. The solid cover prevents debris from entering the drain which should be cleaned up before washdown. Square adjustable strainer is used for floors that are finished of material or straight line patterns. Membrane clamp is provided to secure the waterproofing membrane.

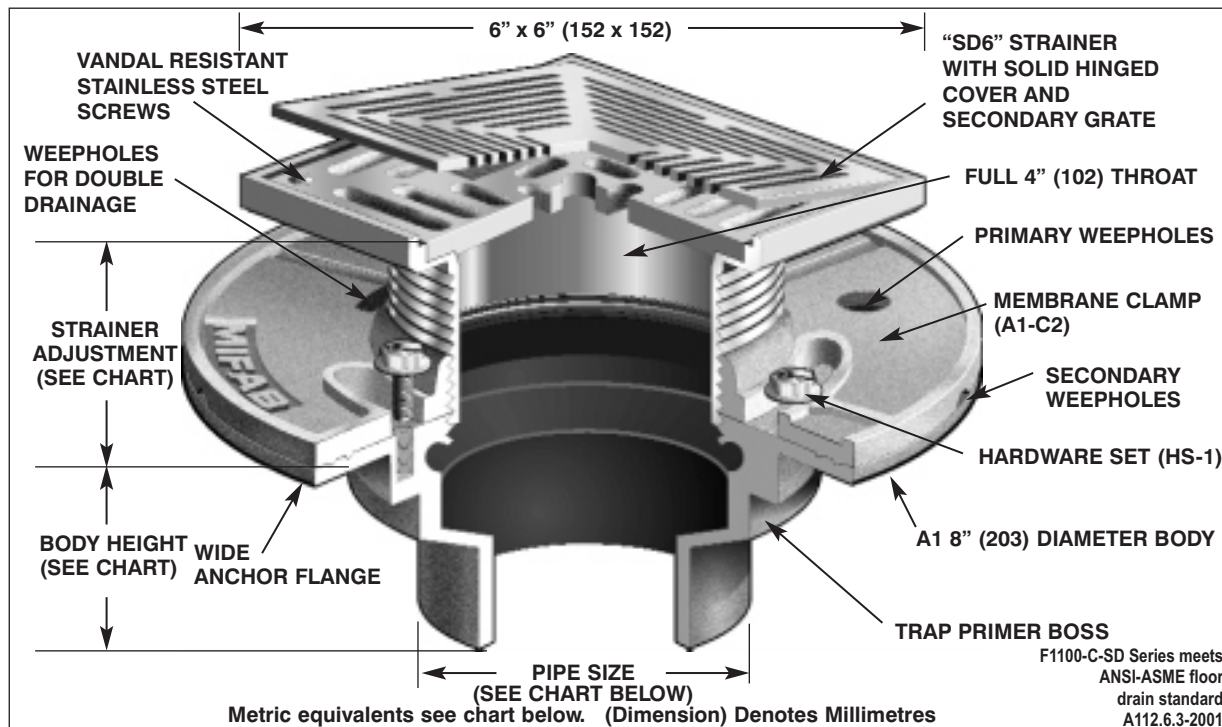

**PARTS:**



A1 BODY



SD6-(\*)  
(\*) Denotes Strainer Finish (-1 or -3)



A1-C2

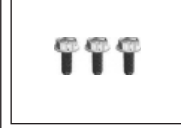

HS-1

STRAINER SIZE	STRAINER ADJUSTMENT		ANSI/ASME RATING		PIPE SIZE	BODY HEIGHT				
	MIN	MAX	FREE AREA	LOAD RATING N.B. (-1)		NO HUB (STANDARD)	PUSH ON (P)	THREADED (T)	INSIDE CAULK (X)	PVC/ABS (-30)/(-31)
6" x 6" (152 x 152)	2" (51)	3 1/8" (79)	12 in <sup>2</sup> (7700 <sup>2</sup> )	UP TO 2,000 LBS.	2" (51)	3" (76)	3 3/8" (86)	2 1/4" (57)	3 3/4" (95)	2 15/16" (75)
					3" (76)	3" (76)	3 3/8" (86)	2 5/8" (67)	3 3/4" (95)	3 3/4" (95)
					4" (102)	3" (76)	3 3/8" (86)	2 5/8" (67)	3 3/4" (95)	3 3/4" (95)
					5" (127)	3" (76)	—	2 5/8" (67)	3 3/4" (95)	—
					6" (152)	3 1/4" (83)	6 1/2" (165)	—	—	—

<b>SUFFIX</b>	<b>OPTIONAL VARIATIONS:</b>	<b>SUFFIX</b>		<b>SUFFIX</b>	
-1	Nickel bronze strainer	-34	Closure plug	-C1	Clamp ring for low rough-in (min. 15/16" (24))
-3	Stainless steel strainer	-40	Underdeck clamp	(Standard)	No hub outlet
-5	Sediment bucket	-41	Sump receiver	P	Push on outlet
-6	Security screws (T-20 Torx & pin)	-90	Threaded side outlet (2", 3", 4") (cast iron only)	-PA	Pennsylvania Steel
-7	1/2" trap seal primer connection	-90NH	No hub side outlet (2", 3", 4") (cast iron only)	T	Act compliant product
-8	Backwater valve (2", 3", 4")	-95	Client logo	X	Threaded outlet (2", 3", 4")
-11	Acid resistant epoxy coated body	-ARRA	ARRA (Stimulus Act) compliant product	-Z	Inside caulk outlet
-13	Galvanized body	-BA	Buy American Act compliant product		Extended wide elastomeric flange
-15	Extension				
-21	Secondary flat stainless steel strainer (2", 3", 4")				
-28	Stainless steel body (Type 304)				
-30	PVC socket connection body				
-31	ABS socket connection body				

Job Name: \_\_\_\_\_ Page No: \_\_\_\_\_  
 Section No: \_\_\_\_\_ Contractor: \_\_\_\_\_  
 Schedule No: \_\_\_\_\_ Purchase Order No: \_\_\_\_\_

MIFAB reserves the right to make changes in material and design without formal notice and obligation. USA: 1-800-465-2736 www.mifab.com CAN: 1-800-387-3880