

Location: _____



F1580

24" x 24" HEAVY DUTY DEEP SUMP DRAIN WITH BOTTOM OUTLET

Specification: MIFAB Series F1580 powder epoxy coated deep sump drain with secondary dome strainer, bottom outlet and extra heavy duty 24" x 24" (610 x 610) two section ductile iron grates with a free area of 200 square inches (129,032²). Grates to have maximum 13/16" (21) openings.

Function: Used in industrial factories, mechanical rooms, parking garages and other membrane finished areas. 24" x 24" tractor grate is used with all types of poured finished floors.

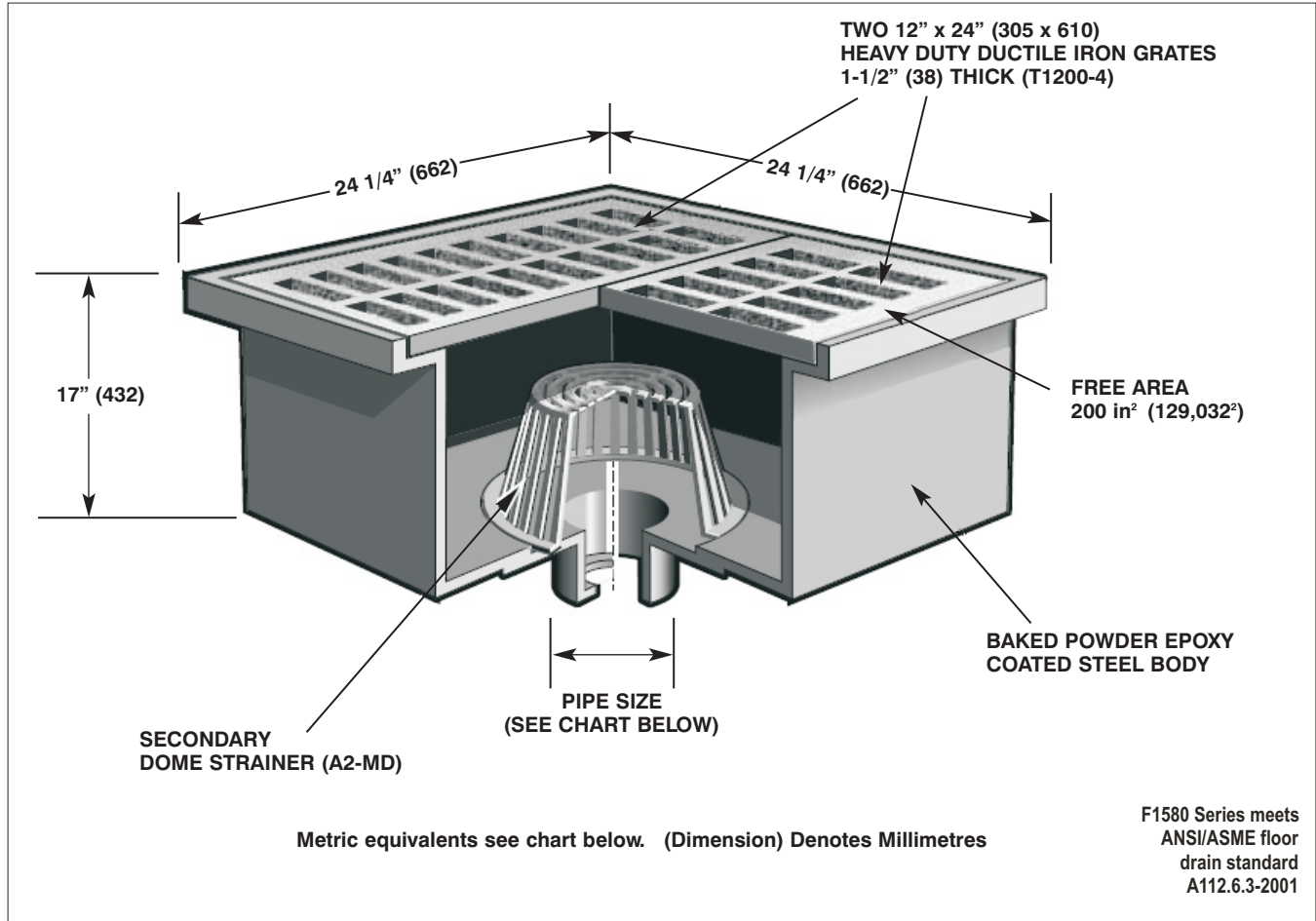

MODEL NO.	NO HUB PIPE SIZE
F1580-A	2" (51)
F1580-B	3" (76)
F1580-C	4" (102)
F1580-D	6" (152)
F1580-E	

- SUFFIX OPTIONAL VARIATIONS:**
- 3 Stainless steel veneer top assembly
 - 4 Ductile iron grates
 - 6 Security screws (TR30 Torx & pin)
 - 8 Backwater valve (2", 3", 4")
 - 12 Galvanized top assembly
 - 13 Galvanized body
 - 28 Stainless steel body (Type 304)

- SUFFIX**
- ARRA ARRA (Stimulus Act) compliant product
 - BA Buy American Act compliant product
 - FL Anchor flange
 - FLC Anchor flange and membrane clamp
 - PA Pennsylvania Steel Act compliant product
- (Specify) Special outlet size

Job Name: _____ Page No: _____
 Section No: _____ Contractor: _____
 Schedule No: _____ Purchase Order No: _____

MIFAB reserves the right to make changes in material and design without formal notice and obligation.