

Location: _____



MC-10-EXT

HORIZONTAL, ADJUSTABLE, WATER CLOSET CARRIER FOR ADA IN MIDDLE OF BATTERY

Specification: MIFAB® Series MC-10-EXT (Specify L for left or R for right design) single, horizontal, adjustable, high rough-in water closet carrier with lacquered cast iron fitting, 4" (102) no hub waste, 2" (51) no hub vent connection, lacquered cast iron gasketed adjustable faceplate, universal floor mounted cast iron foot supports, adjustable 8" tapered thread ABS nipple with integral test cap, neoprene bowl gasket, hardware, threaded rod protectors, polished chrome plated finishing cap nuts and rear anchor tie down support.

Function: Used in the middle of horizontal batteries where the water closet must be elevated 3" (76) higher than the normal rough-in height to accommodate fixtures for wheelchair users. The elevated inlet flange permits the water closet to be installed at any position in the battery. Typical with off the floor plumbing fixtures that are wall mounted and have no contact with the finished floor. The closet carrier is completely concealed within the wall and supports the load of the fixture through a faceplate and foot support system that is anchored to the floor. Sanitation underneath the fixture is more efficiently and economically maintained when installed off of the floor compared to floor mounted.

Note: 10 1/2" (267) minimum space required between front of foot and rear of anchor support. 8" (203) minimum in wall space required between back of rear anchor support and back of in wall foot supports.

Note: Foot supports and faceplate are assembled at the factory before shipment in the typical siphon jet water closet configuration and are reversible for the blowout water closet design.

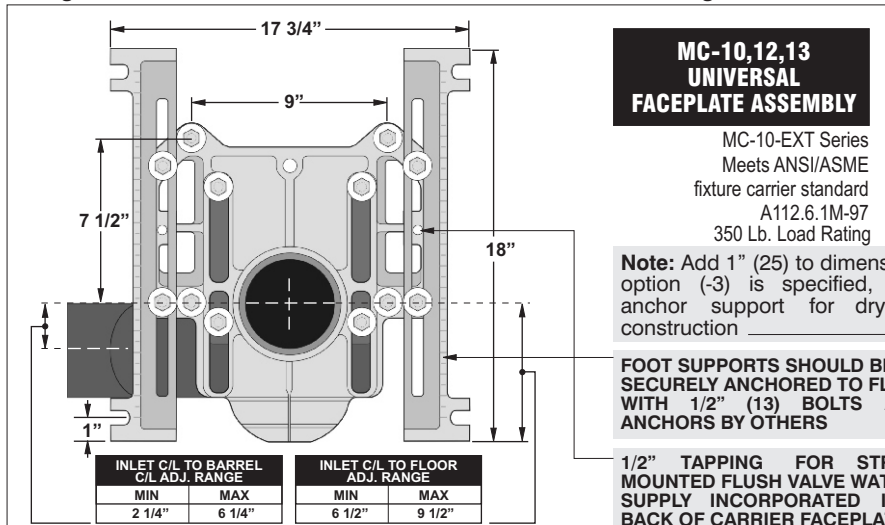

MC-10,12,13 UNIVERSAL FACEPLATE ASSEMBLY

MC-10-EXT Series
Meets ANSI/ASME
fixture carrier standard
A112.6.1M-97
350 Lb. Load Rating

Note: Add 1" (25) to dimension if option (-3) is specified, rear anchor support for drywall construction

FOOT SUPPORTS SHOULD BE SECURELY ANCHORED TO FLOOR WITH 1/2" (13) BOLTS AND ANCHORS BY OTHERS

1/2" TAPPING FOR STRUT MOUNTED FLUSH VALVE WATER SUPPLY INCORPORATED INTO BACK OF CARRIER FACEPLATE

Note: 8" tapered thread ABS nipple shipped standard with MC-10 Series carriers. The universal faceplate assembly accepts all nipple variations, rolling thread (-OR), cast iron (-CI) and tapered thread ABS with adjustable horn (-AH).

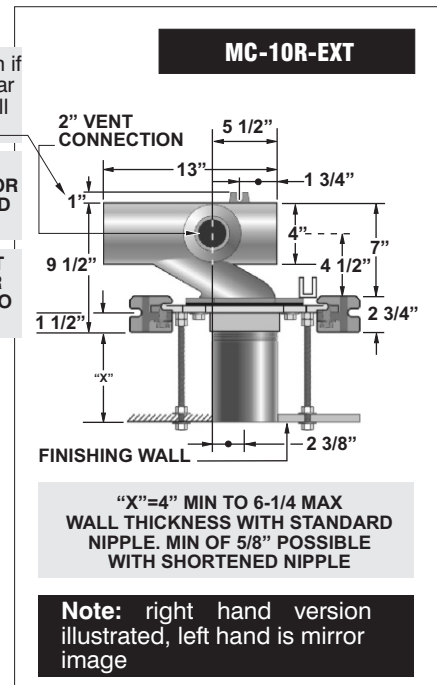

MC-10R-EXT

"X"=4" MIN TO 6-1/4" MAX WALL THICKNESS WITH STANDARD NIPPLE. MIN OF 5/8" POSSIBLE WITH SHORTENED NIPPLE

Note: right hand version illustrated, left hand is mirror image

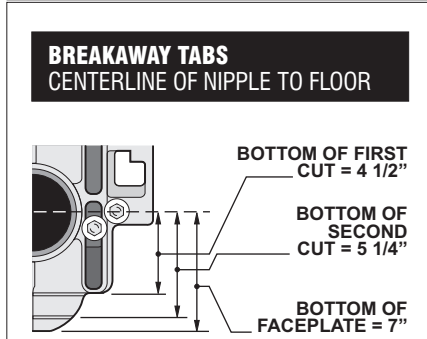

BREAKAWAY TABS CENTERLINE OF NIPPLE TO FLOOR

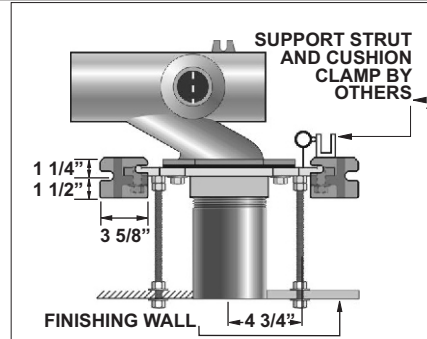

SUPPORT STRUT AND CUSHION CLAMP BY OTHERS

SUFFIX	OPTIONAL VARIATIONS:	-OR12	12" rolling thread ABS nipple
-AH8	8" ABS nipple with adjustable horn	-PA	Pennsylvania Steel Act compliant product
-AH12	12" ABS nipple with adjustable horn	-PFAB	Prefabricated carrier
-BA	Buy American Act compliant product	-R	Right hand fitting
-CI-4	4" rolling thread cast iron nipple	-1	Finishing / Tiling frame
-CI-6	6" rolling thread cast iron nipple	-10	Auxiliary support, recommended with nipple lengths over 12"
-CI-8	8" rolling thread cast iron nipple	-12	12" tapered thread ABS nipple
-CI-12	12" rolling thread cast iron nipple	-13	Galvanized cast iron
-CI-24	24" rolling thread cast iron nipple	-14	Vandal proof finish trim
-FM	Floor mount, back outlet fixture support	-17	Test plug for custom and cast iron nipples
-HD	Heavy duty 500 lb. load rated carrier	-19	Nipple wrench
-HD-750	Heavy duty 750 lb. load rated carrier	-20	Flush valve support
-HDX	Extra heavy duty 1,000 lb. load rated carrier	-27	2" auxiliary inlet
-L	Left hand fitting	-37	37" long extended barrel
-OR8	8" rolling thread ABS nipple		

Job Name: _____ Page No: _____
 Section No: _____ Contractor: _____
 Schedule No: _____ Purchase Order No: _____