

Location: \_\_\_\_\_



# MC-10-HD

**HEAVY DUTY, 500 LB. LOAD RATED  
HORIZONTAL, ADJUSTABLE,  
WATER CLOSET CARRIER**

**Specification:** MIFAB® Series MC-10-HD (Specify -L for left or -R for right design) single, horizontal, adjustable, water closet carrier for 500 lb. load rating with lacquered cast iron fitting, 4" (102) no hub waste, 2" (51) no hub vent connection, lacquered cast iron gasketed adjustable faceplate, universal floor mounted cast iron foot supports, adjustable 8" tapered thread ABS nipple with integral test cap, neoprene bowl gasket, hardware, threaded rod protectors, polished chrome plated finishing cap nuts and rear anchor tie down support.

**Function:** Used with off the floor plumbing fixtures that are wall mounted and have no contact with the finished floor. The closet carrier is completely concealed within the wall and supports the load of the fixture through a faceplate and foot support system that is anchored to the floor. Sanitation underneath the fixture is more efficiently and economically maintained when installed off of the floor compared to floor mounted. Use of the rear anchor tie down support is required to attain the 500 lb. load rating.

**Note:** 10 1/2" (267) minimum space required between front of foot and rear of anchor support. 8" (203) minimum in wall space required between back of rear anchor support and back of in wall foot supports.

**Note:** Foot supports and faceplate are assembled at the factory before shipment in the typical siphon jet water closet configuration and are reversible for the blowout water closet design.

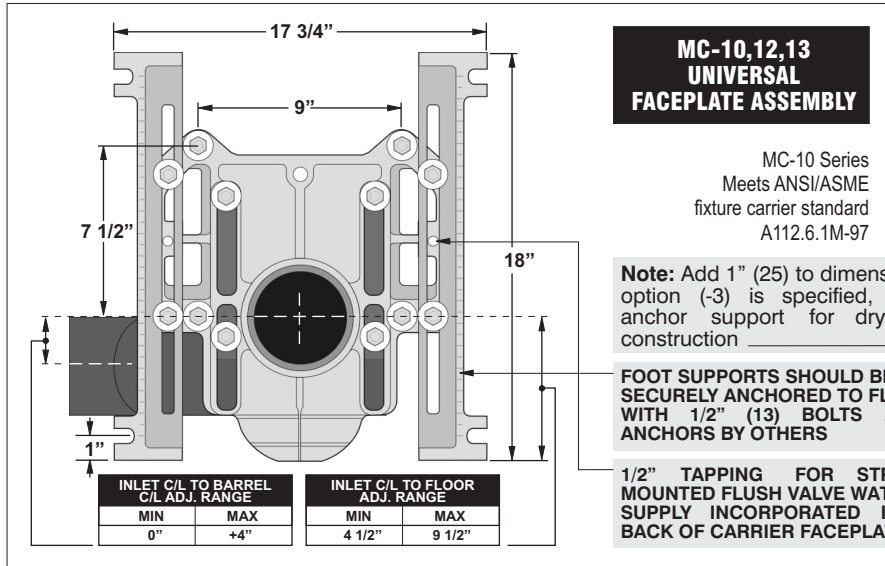

**Note:** 8" tapered thread ABS nipple shipped standard with MC-10 Series carriers. The universal faceplate assembly accepts all nipple variations, rolling thread (-OR), cast iron (-CI) and tapered thread ABS with adjustable horn (-AH).

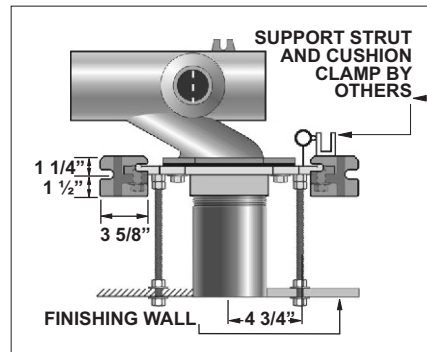
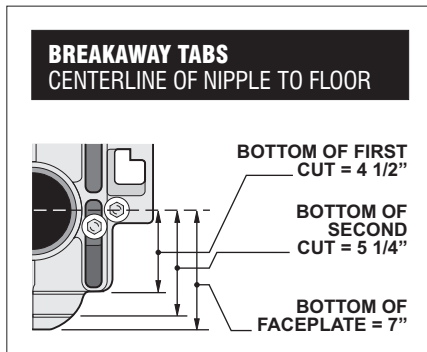
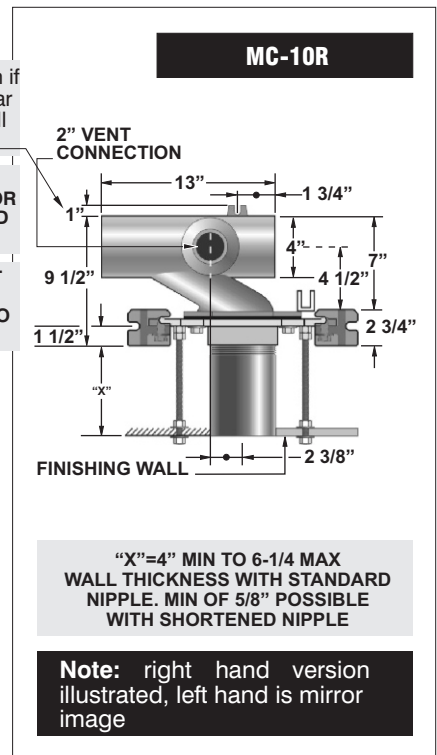

- | SUFFIX  | OPTIONAL VARIATIONS:                          |
|---------|---|
| -AH8    | 8" ABS nipple with adjustable horn            |
| -AH12   | 12" ABS nipple with adjustable horn           |
| -BA     | Buy American Act compliant product            |
| -CI-4   | 4" rolling thread cast iron nipple            |
| -CI-6   | 6" rolling thread cast iron nipple            |
| -CI-8   | 8" rolling thread cast iron nipple            |
| -CI-12  | 12" rolling thread cast iron nipple           |
| -CI-24  | 24" rolling thread cast iron nipple           |
| -FM     | Floor mount, back outlet fixture support      |
| -HD-750 | Heavy duty 750 lb. load rated carrier         |
| -HDX    | Extra heavy duty 1,000 lb. load rated carrier |
| -HS     | Hub and spigot connection                     |
| -L      | Left hand fitting                             |
| -OR8    | 8" rolling thread ABS nipple                  |
| -OR12   | 12" rolling thread ABS nipple                 |

- | SUFFIX |   |
|--------|---|
| -PA    | Pennsylvania Steel Act compliant product                    |
| -PFAB  | Prefabricated carrier                                       |
| -R     | Right hand fitting  |
| -1     | Finishing / Tiling frame                                    |
| -10    | Auxiliary support, recommended with nipple lengths over 12" |
| -12    | 12" tapered thread ABS nipple                               |
| -13    | Galvanized cast iron  |
| -14    | Vandal proof finish trim                                    |
| -17    | Test plug for custom and cast iron nipples                  |
| -19    | Nipple wrench   |
| -20    | Flush valve support   |
| -27    | 2" auxiliary inlet  |
| -37    | 37" long extended barrel                                    |

Job Name: _____	Page No: _____
Section No: _____	Contractor: _____
Schedule No: _____	Purchase Order No: _____

MIFAB reserves the right to make changes in material and design without formal notice and obligation.