

Location: _____



MC-31

HANGER PLATE CARRIER WITH BEARING PLATE AND TWO UPRIGHTS

Specification: MIFAB® Series MC-31 single lavatory hanger plate carrier with universal, adjustable, top support plate. Complete with lacquered 2" x 1" x 1/8" thick structural steel uprights with 3" x 4 1/2" welded steel feet and mounting hardware.

Function: Used to support wall-hung fixtures such as urinals and water coolers that are independent of the wall. Designed for use in conjunction with the fixture hanger plate supplied by the fixture manufacturer.

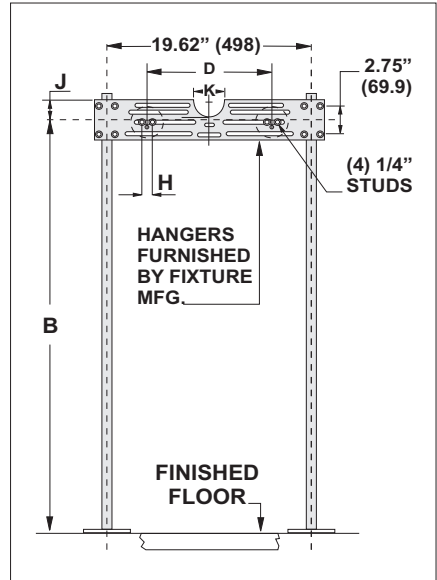
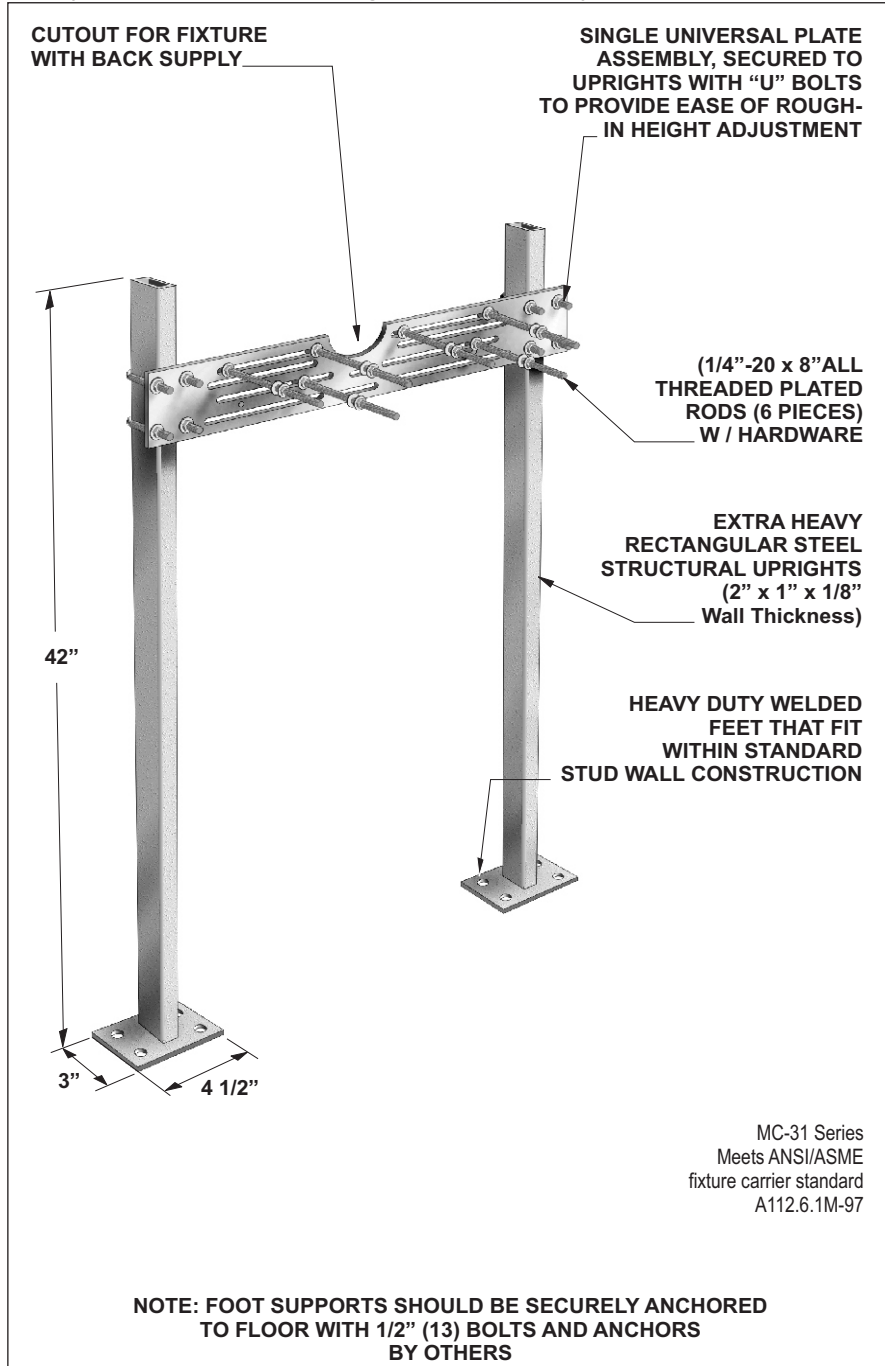

BASE DETAIL

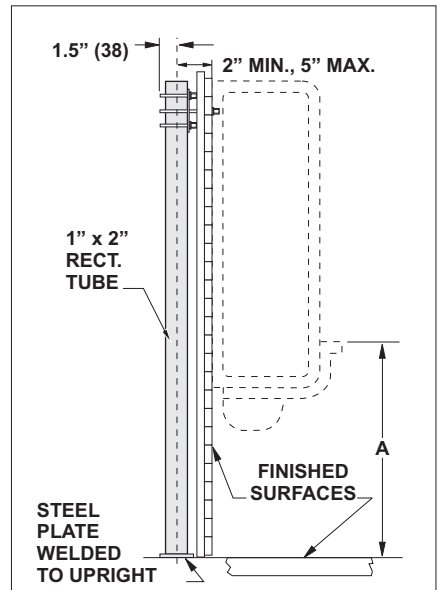
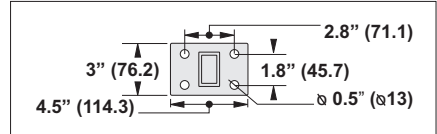

Note: See the various fixture dimensional rough-in guides on the www.mifab.com website.

SUFFIX OPTIONAL VARIATIONS:

- A Stud length over 8" (specify)
- B Floor to ceiling uprights
- BA Buy American Act compliant product
- C Two hanger plates (three uprights for corner mounted lavatory)

SUFFIX

- HDH Heavy duty hanger
- PA Pennsylvania Steel Act compliant product
- PFAB Prefabricated carrier
- see MC-31D Back to back system
- 20 Flush valve support

Job Name: _____ Page No: _____

Section No: _____ Contractor: _____

Schedule No: _____ Purchase Order No: _____