

Location: _____



MC-32D

BACK TO BACK HANGER PLATE CARRIER WITH BEARING PLATES AND TWO UPRIGHTS

Specification: MIFAB® Series MC-32D hanger plate carrier with universal, adjustable, top support plates and bottom bearing plates. Complete with lacquered 2" x 1" x 1/8" thick structural steel uprights with 3" x 4 1/2" welded steel feet and mounting hardware.

Function: Used to support back to back wall-hung fixtures such as urinals and water coolers that are independent of the wall. Bottom bearing plate provides extra support for the fixture. Designed for use in conjunction with the fixture hanger plate supplied by the fixture manufacturer.

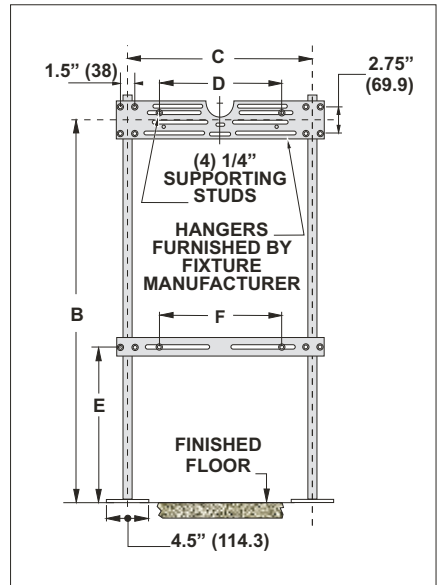
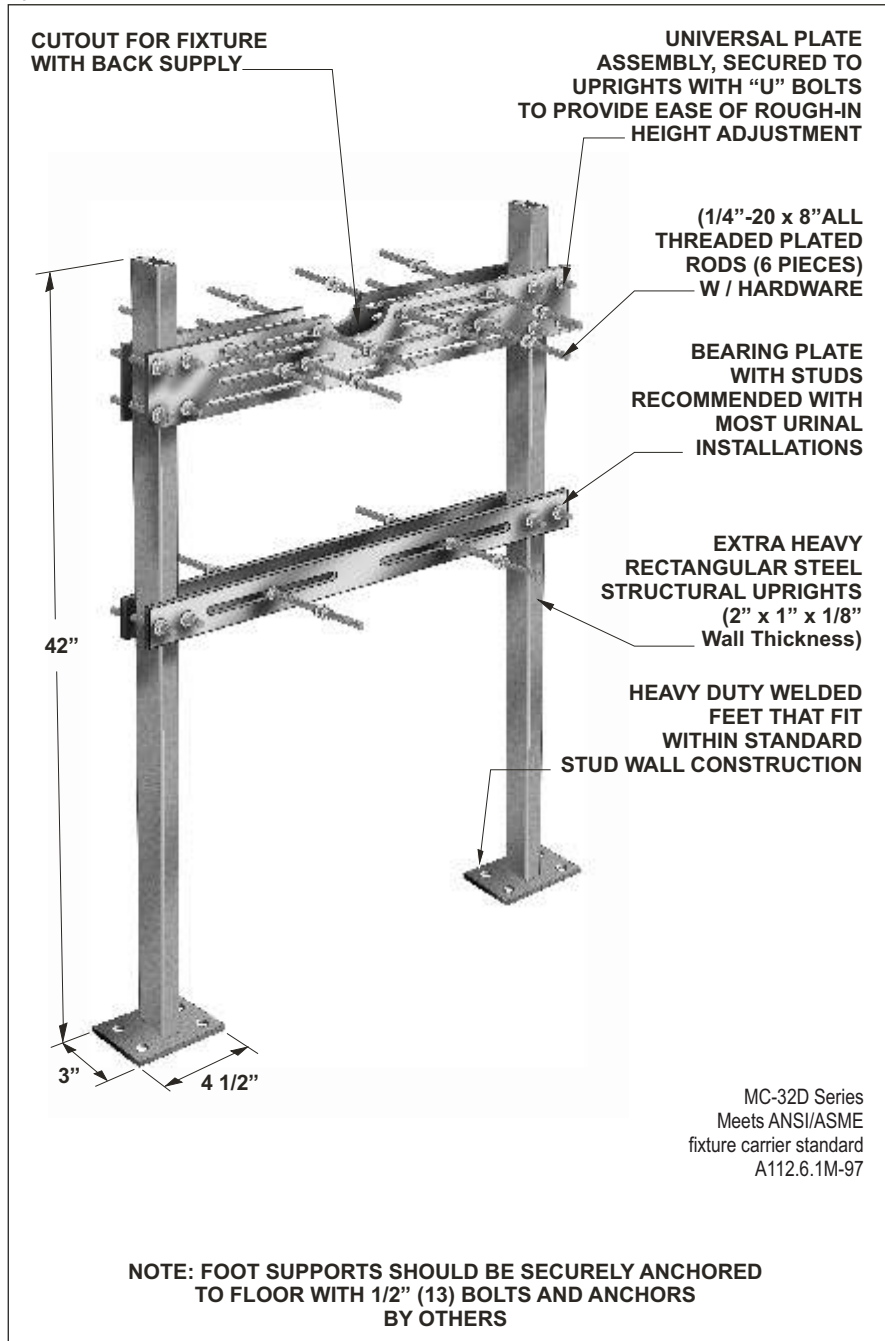

BASE DETAIL

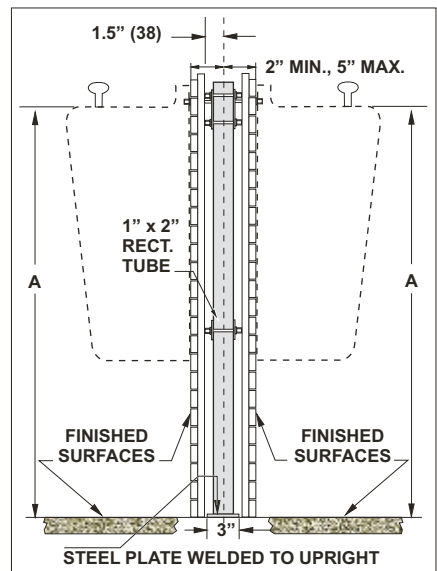
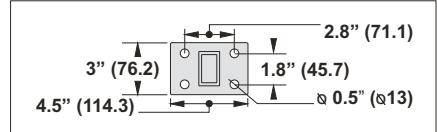

Note: See the various fixture dimensional rough-in guides on the www.mifab.com website.

SUFFIX OPTIONAL VARIATIONS:

- A Stud length over 8" (specify)
- B Floor to ceiling uprights
- BA Buy American Act compliant product
- C Two hanger plates (three uprights for corner mounted lavatory)

SUFFIX

- HDH Heavy duty hanger
- PA Pennsylvania Steel Act compliant product
- PFAB Prefabricated carrier
- 20 Flush valve support

Job Name: _____	Page No: _____
Section No: _____	Contractor: _____
Schedule No: _____	Purchase Order No: _____

MIFAB reserves the right to make changes in material and design without formal notice and obligation.

USA: 1-800-465-2736 www.mifab.com CAN: 1-800-387-3880