

Location: \_\_\_\_\_



# MC-34D

## BACK TO BACK HANGER PLATE AND EXPOSED ARM LAVATORY CARRIER WITH TWO UPRIGHTS

**Specification:** MIFAB® Series MC-34D back to back hanger plate and exposed arm lavatory carrier with two universal, adjustable, top support plates and four white, lacquered, adjustable, cast iron exposed support arms assembled to lacquered cast iron invertible and adjustable arm supporting brackets. Complete with two lacquered 2" x 1" x 1/8" thick structural steel uprights with 3" x 4 1/2" welded steel feet and mounting hardware.

**Function:** Used to support back to back heavy duty wall-hung lavatories that are independent of the wall. Heavy duty cast iron support arms provide extra support for the fixture. Designed for use in conjunction with the fixture hangar plate supplied by the fixture manufacturer.

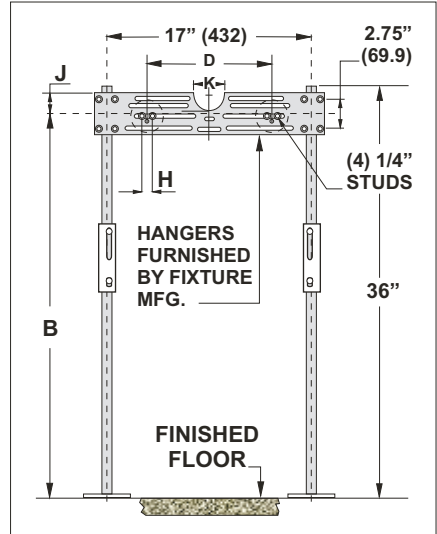
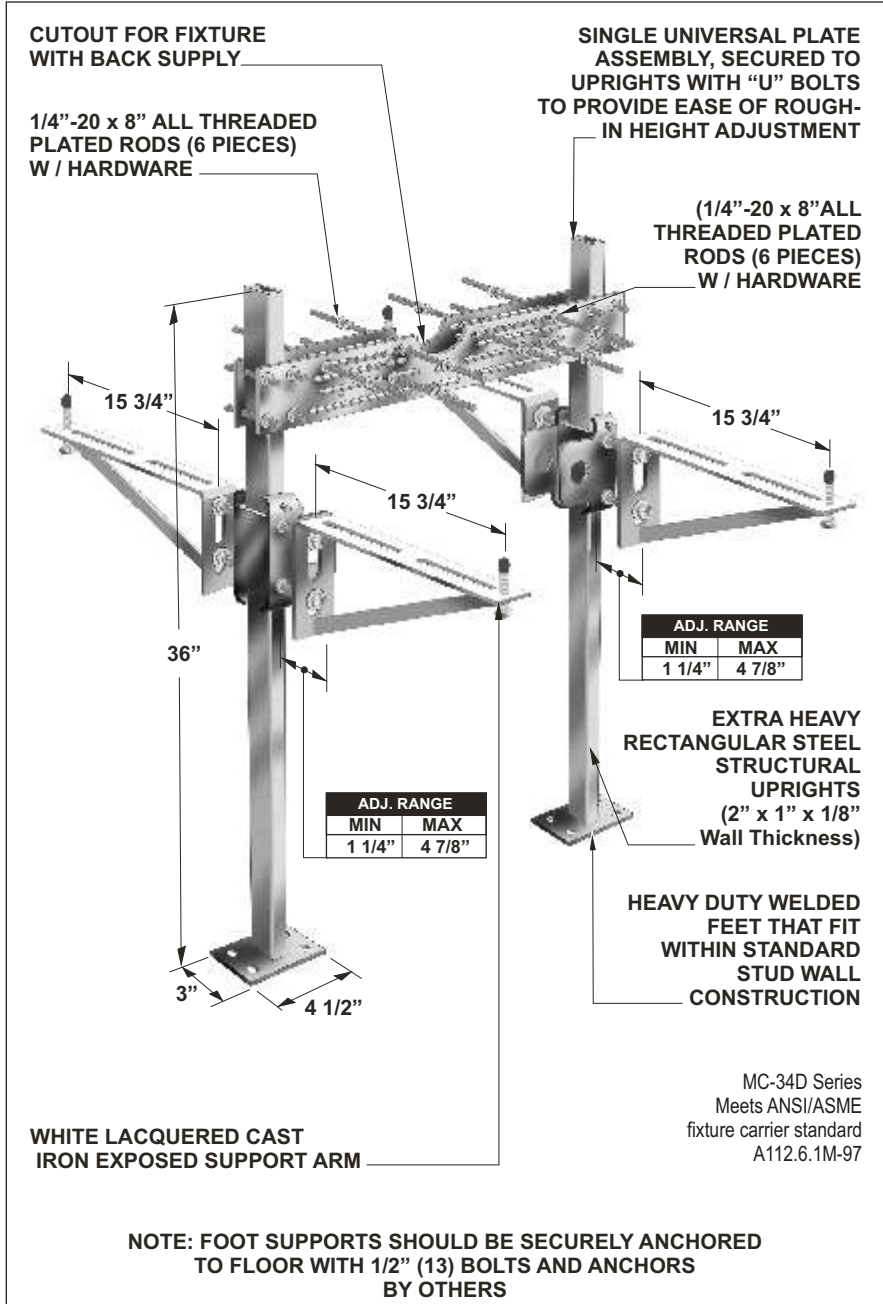

### BASE DETAIL

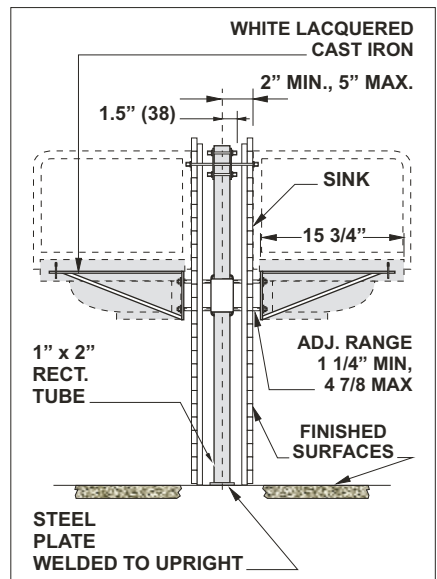
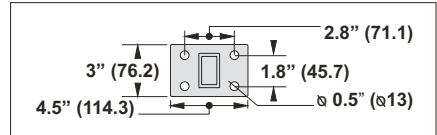

**Note:** See the various fixture dimensional rough-in guides on the [www.mifab.com](http://www.mifab.com) website.

**SUFFIX OPTIONAL VARIATIONS:**

- A Stud length over 8" (specify)
- BA Buy American Act compliant product
- G Wall support plate
- HDH Heavy duty hanger
- I 3/8" threaded eye bolts for cast iron lavs (H-1028)

**SUFFIX**

- PA Pennsylvania Steel Act compliant product
- PFAB Prefabricated carrier
- Z Higher uprights (over 36")
- 14 Vandal proof finish trim

Job Name: \_\_\_\_\_ Page No: \_\_\_\_\_  
 Section No: \_\_\_\_\_ Contractor: \_\_\_\_\_  
 Schedule No: \_\_\_\_\_ Purchase Order No: \_\_\_\_\_