

Location: _____



MC-41D

BACK TO BACK FIXTURE CARRIER WITH CONCEALED ARMS

Specification: MIFAB® Series MC-41D floor mounted back to back concealed arm lavatory carrier with lacquered, adjustable, ductile iron concealed support arms. Complete with lacquered cast iron invertible and adjustable arm supporting brackets, adjustable steel nipples with locknut and set screws, alignment rod, two lacquered 2" x 1" x 1/8" thick structural steel uprights with 3" x 4 1/2" welded steel feet and fixture leveling and locking hardware.

Function: Used to support back to back off-the-floor fixtures so that the vertical load bearing components are concealed within the wall. The fixture carrier has no contact with the finished floor inside of the room.

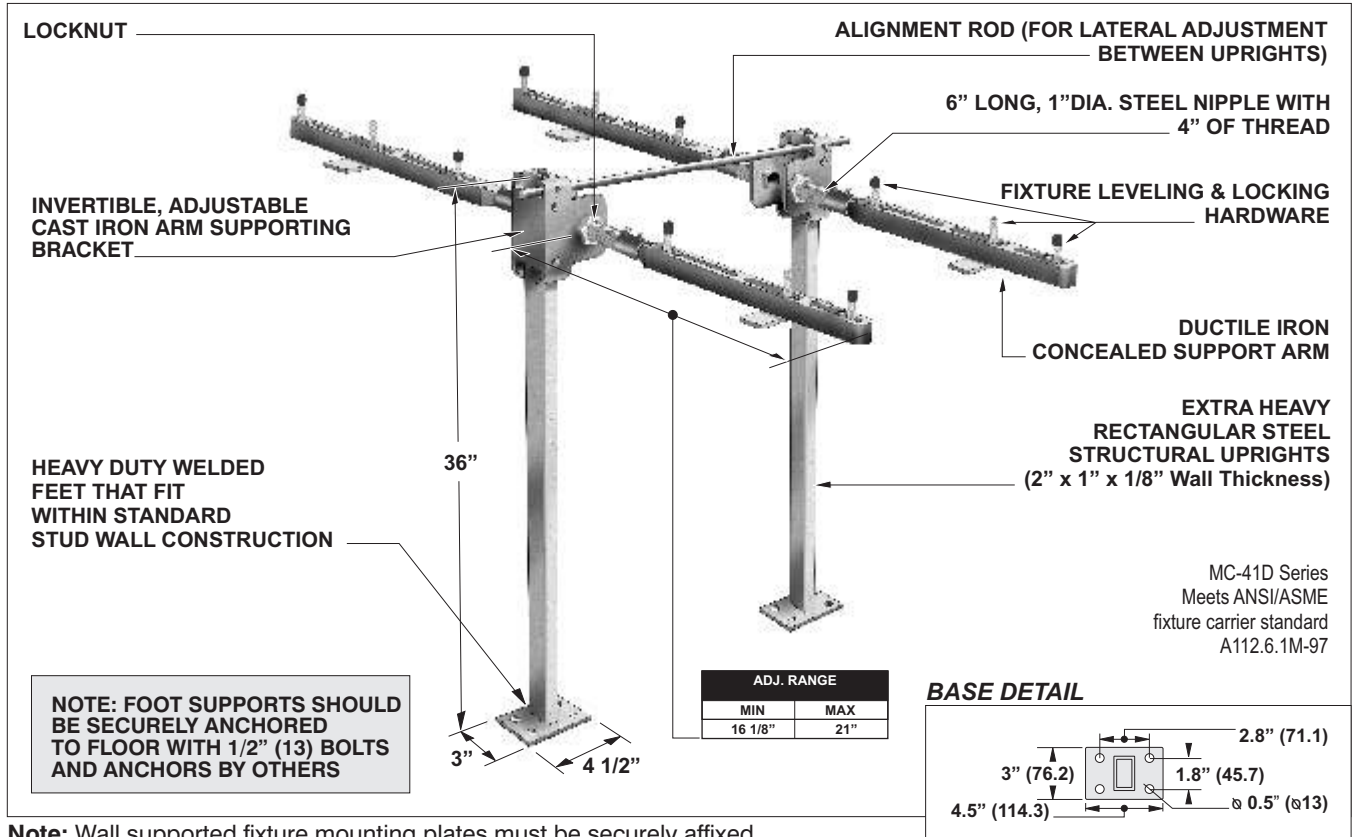

Note: Wall supported fixture mounting plates must be securely affixed (with suitable hardware by others) to a wall fully capable of bearing the weight of the plate and fixture.

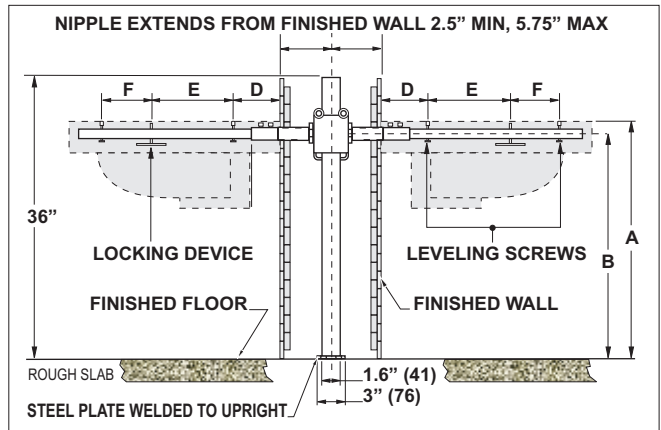
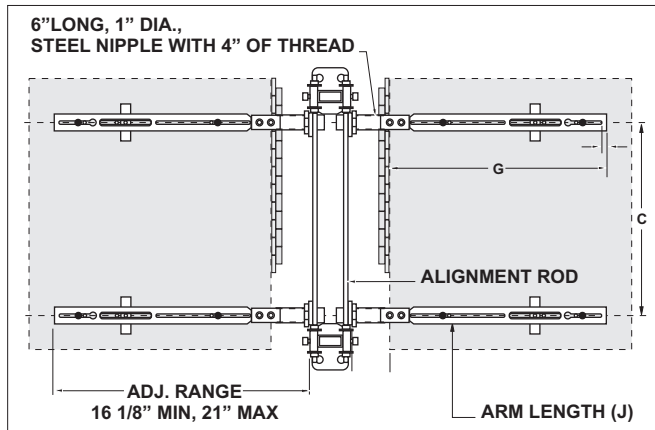

- SUFFIX OPTIONAL VARIATIONS:**
- A Nipple length over 6" (specify)
 - B Floor to ceiling uprights (specify height required)
 - BA Buy American Act compliant product
 - E2 2" chrome plated escutcheons (pair)
 - G Wall support valve plate
 - NW 1" x 5/8" slots through each upright to accommodate piping for narrow wall installations

- SUFFIX**
- PA Pennsylvania Steel Act compliant product
 - PFAB Prefabricated carrier
 - see MC-42D Parapelgic Rough-in
 - 32 Foot pedal mounting plate
 - 88 Mounting hardware for cast iron wall hung lavs

Job Name: _____ Page No: _____

Section No: _____ Contractor: _____

Schedule No: _____ Purchase Order No: _____