

Location: _____



MC-55

WALL MOUNTED LAVATORY SUPPORT WITH EXPOSED ARMS AND BACKING PLATES

Specification: MIFAB® Series MC-55 wall mounted exposed arm lavatory carrier with white, lacquered, adjustable, cast iron exposed support arms. Complete with lacquered cast iron adjustable wall plate with mounting studs, backing plates and fixture leveling hardware.

Function: Used to secure wall-hung lavatories to the wall in areas where a floor mounted carrier cannot be installed. Backing plates provide additional rigidity to system. The wall structure must be strong enough to bear the weight of the fixture. Heavy duty exposed cast iron supports provide extra support for the fixture.

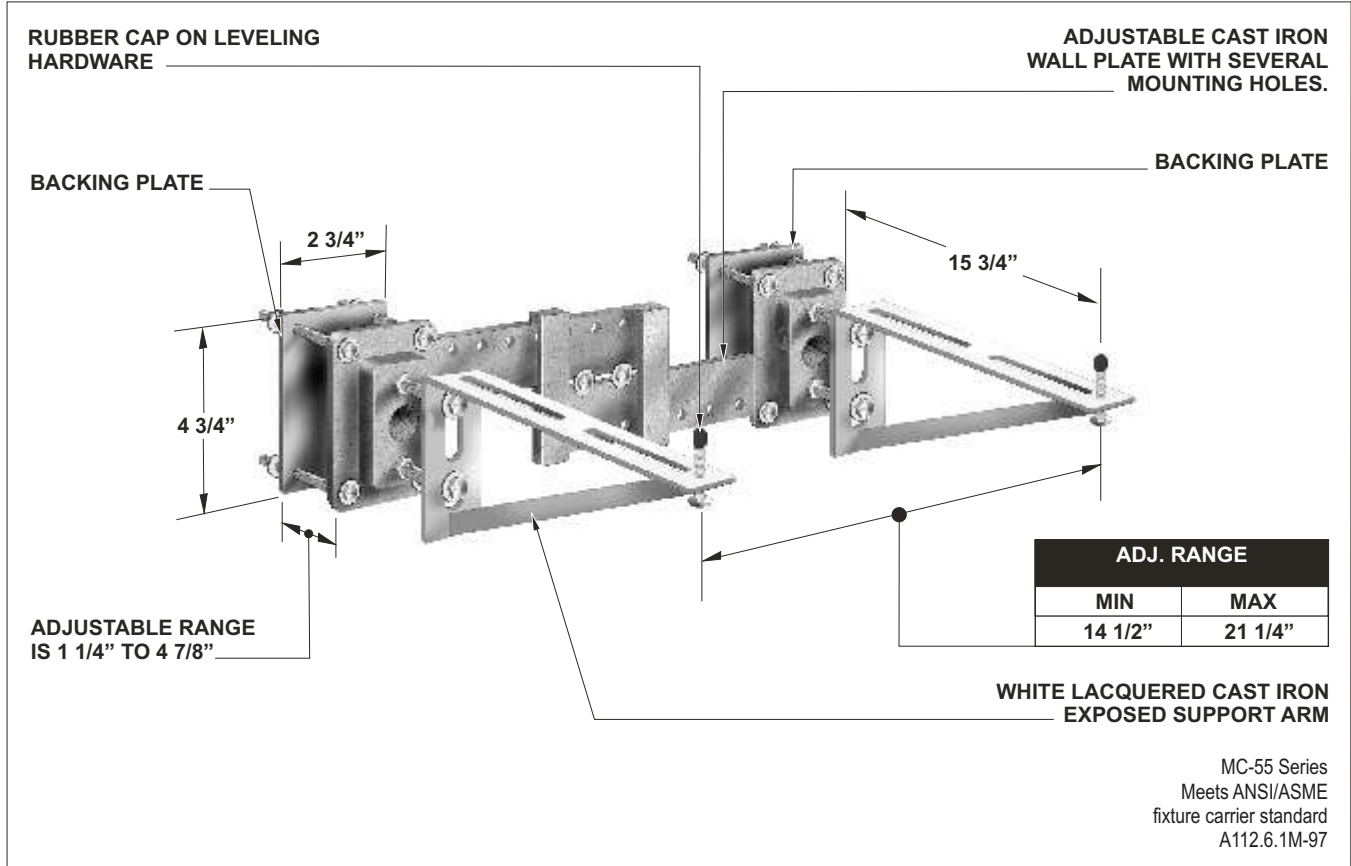

Note: Wall supported fixture mounting plates must be securely affixed (with suitable hardware by others) to a wall fully capable of bearing the weight of the plate and fixture.

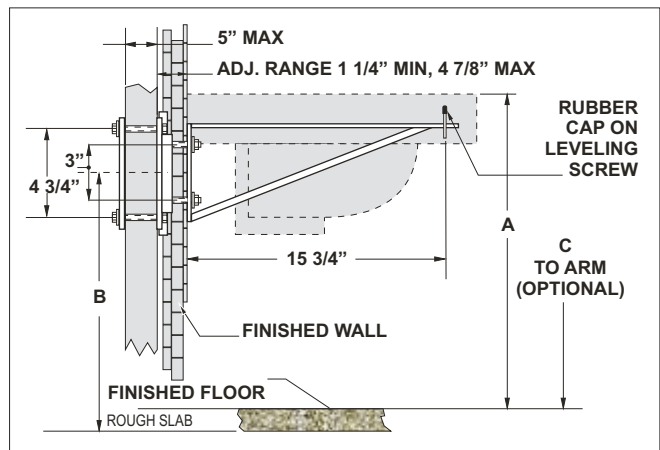
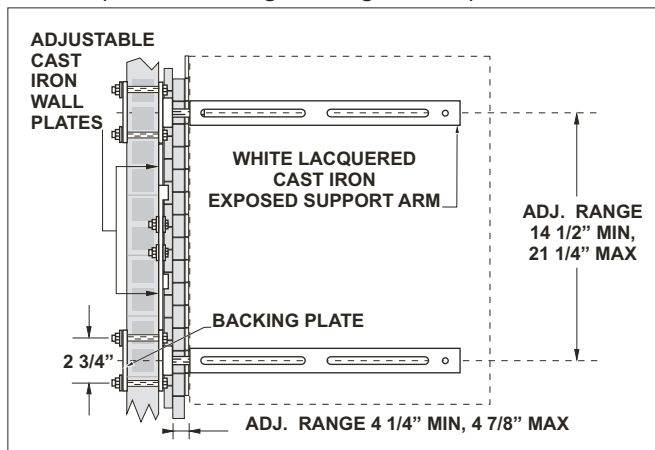

- SUFFIX OPTIONAL VARIATIONS:**
- A Stud length over 6" (specify)
 - BA Buy American Act compliant product
 - F Bar support valve plate

- SUFFIX**
- PA Pennsylvania Steel Act compliant product
 - 14 Vandal proof finish trim

Job Name: _____ Page No: _____

Section No: _____ Contractor: _____

Schedule No: _____ Purchase Order No: _____

MIFAB reserves the right to make changes in material and design without formal notice and obligation.

USA: 1-800-465-2736 www.mifab.com CAN: 1-800-387-3880