

Location: _____



MI-G-L-SDH

LOW ROUGH IN HYDRO MECHANICAL GREASE INTERCEPTOR WITH DRAW OFF HOSE

Specification: MIFAB Series MI-G-L-SDH ____ sanitary acid resistant, powder epoxy coated inside and outside fabricated 10 gauge steel hydro mechanical grease interceptor with flow rating of ____ (indicate) and grease holding capacity of ____ (indicate). Unit shall include: removable baffle assembly and cross bar, internal deep seal trap covered by lid, sewer gas stopper, securing bolt(s), external vented flow control fitting, internal air relief by pass, feet underneath interceptor to elevate it 1/2" off the ground, internal steel cone, flexible draw-off hose and cap, hose clamp, line shut off valve and steel acid resistant, powder epoxy coated, non skid, rectangular gasketed lid(s).

Function: Used in restaurants, kitchens, institutions, and other types of food processing areas where fat, oil and grease (FOG) drains with the wastewater. Semi-automatic draw-off valve and hose design permits removal of accumulated FOG without cover removal. Follow the manufacturer's maintenance instructions to liquefy the accumulated grease before removal through the draw-off hose. This cleaning process is more efficient compared to standard types of grease interceptors. External flow control fitting must be installed according to manufacturer's instructions to control rate of flow into the interceptor and therefore, the operating efficiency. Interceptor may be installed on the ground, semi recessed or flush with the floor. Standard acid resistant, powder epoxy coated lid and body ensures maximum protection from contaminants. Sewer gas stopper prevents foul odors from entering the kitchen area through the interceptor. 1/2" feet underneath the interceptor elevates the bottom steel plate from the wet ground.

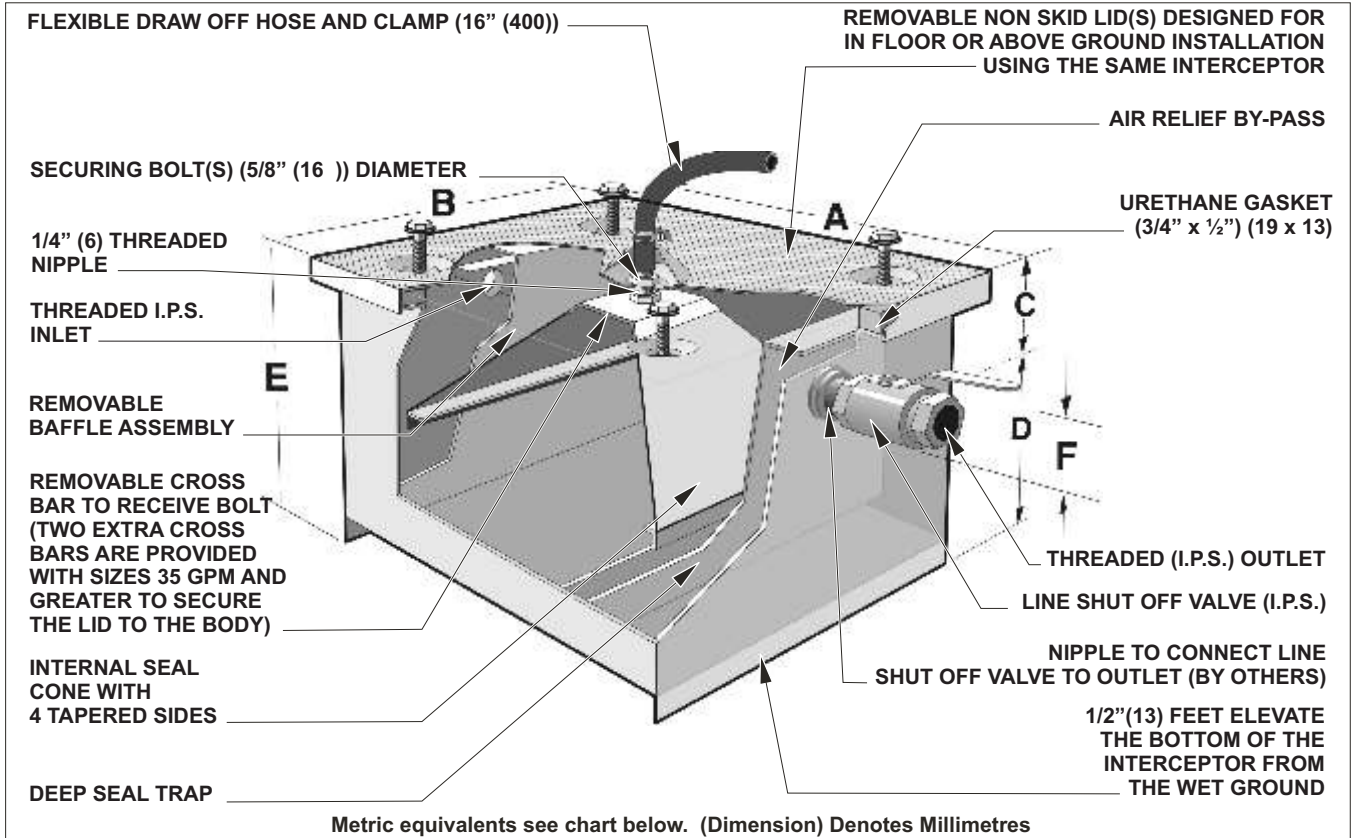

Note: The "C" dimension detailed above is from either the middle of the inlet or the outlet to the top the interceptor. The inlet and outlet dimensions are always the same.

MODEL NO.	US GPM	GREASE CAP. LBS.	A	B	C	D	E	F	NO. OF LIDS	NO. OF BOLTS	SHIPPING WEIGHT (lbs.)	WEIGHT WHEN FILLED WITH WATER (lbs.)	LIQUID HOLDING CAP. (U.S.G.)
MI-G-L-SDH-20	20	40	36.5" (927)	26.5" (673)	4" (102)	7" (178)	11" (279)	3" (76)	1	18	160	277	20.13
MI-G-L-SDH-35	35	70	44.5" (1130)	30.5" (775)	4" (102)	7" (178)	11" (279)	3" (76)	1	18	210	389	28.84
MI-G-L-SDH-50	50	100	48.5" (1232)	32.5" (725)	4" (102)	7" (178)	11" (279)	3" (76)	1	18	250	464	33.77

Note: Reduce the "A" and "B" dimensions by 1" (25) to determine the actual body length and width dimensions. The lid overhangs the body by 1/2" (13) on all four sides.

SUFFIX	OPTIONAL VARIATIONS:	SUFFIX	SUFFIX	
-AL	Aluminum lid(s)	-EP	Enzyme port	
-AP	Anode pack	-FL	Anchor flange	
-BA	Buy American Act compliant product	-FLM	Anchor flange and membrane clamp	
specify MI-CSD	Extension "C" as required	-HD	Heavy duty reinforced lid(s)	
-DP	Dosing pump	-H-20	H-20 traffic rated lid	
			-HLA	High level alarm
			-SS	Stainless steel interceptor (Type 304)
			-TL	Lid (s) to receive tile or terrazzo

Job Name: _____	Page No: _____
Section No: _____	Contractor: _____
Schedule No: _____	Purchase Order No: _____

MIFAB reserves the right to make changes in material and design without formal notice and obligation.

USA: 1-800-465-2736 www.mifab.com CAN: 1-800-387-3880