



R1220-PR

MEDIUM SUMP PROMENADE DECK DRAIN WITH 12" SQUARE TOP

Specification: MIFAB® Series R1220-PR lacquered cast iron medium sump roof drain with 12" diameter anchor flange, large cast iron waterproofing membrane clamp ring with integral gravel stop, square adjustable collar and standard 12" (305) square hinged ductile iron tractor grate with 3/8" (9) maximum width drainage slots and a free area of 51 square inches.

Function: Used in flat roofs and decks designed for promenade or recreational areas. Large square top blends in with tile and brick patterns and has enough free area for efficient drainage of rainwater. Narrow, 3/8" (9) drainage slots prevent debris from entering the drain line. Extra wide anchor flange and membrane clamp with tongue in groove design provides for secure grip of membrane and roof flashing materials. Specify MIFAB's double adjustable extension (Suffix -15) to enable one to adjust the extension independent of the top assembly to the required height and position. This unique design permits one to align the square drain with the square tile or brick pattern.

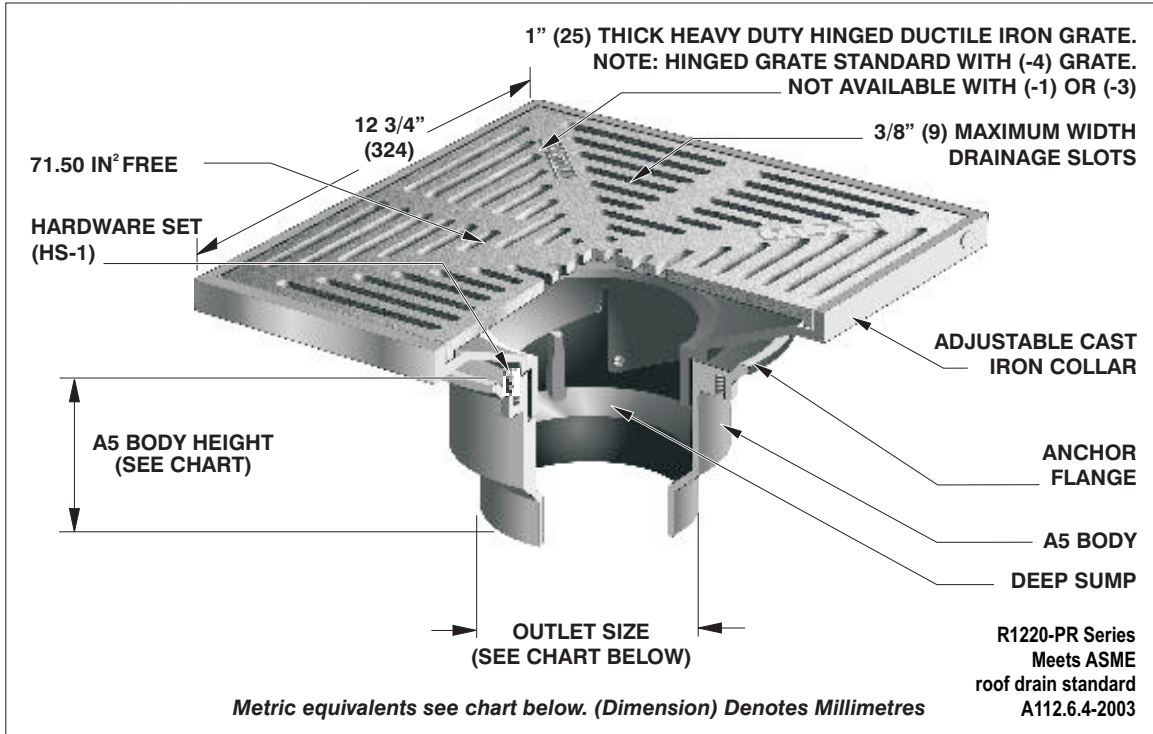

PARTS:



A5 BODY

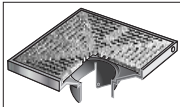

F1440-TA-4



HS-1

Note: Deck opening - 10" (254) with sump receiver 12 3/4" (400)

Note: When used in exterior areas and subject to rainfall, ensure that the free area is equal to twice the transverse (cross sectional) area of the connecting pipe.

PIPE SIZE	BODY HEIGHT		INSIDE CAULK (X)	
	NO HUB (STANDARD)			
2" (51)	6.45"	(161)	6.575"	(167)
3" (76)	6.45"	(161)	6.575"	(167)
4" (102)	6.45"	(161)	6.575"	(167)
6" (152)	6.45"	(161)	6.575"	(167)

SUFFIX

- 1
- 3
- 4
- 5
- 6
- 11
- 12
- 13
- 15
- 21
- (Standard)
- ARRA

OPTIONAL VARIATIONS:

- Nickel bronze (vener)
- Stainless steel (vener)
- Ductile iron grate (standard)
- Sediment bucket
- Vandal proof
- Acid resistant epoxy coating
- Galvanized top assembly
- Galvanized body and top assembly
- Adjustable extension
- Secondary flat stainless steel strainer (2", 3", 4")
- No hub outlet
- ARRA (Stimulus Act) compliant product

SUFFIX

- B Sump receiver
- BA Buy American Act
- Compliant product
- PA Pennsylvania Steel
- Act compliant product
- U Underdeck clamp
- U3 Underdeck clamp with cutaway side
- W-1 Water proofing flange
- X Inside caulk outlet (2", 3", 4", 6")
- XJ Vertical expansion joint (see R1900)
- Z Extended wide elastomeric flange

Job Name: _____ Page No: _____
 Section No: _____ Contractor: _____
 Schedule No: _____ Purchase Order No: _____